

4Weeks Workshop Report on Catia

Nuerater Maluth Manyaqng

South Sudan

Learning a new programming language is always a challenge. Here I describe the most important steps and considerations for a new student of Catia software to consider. From 30th May to 30th June 2019, under the guidance of Mr, Mark, I have declared that I have worked with full dedication during these 4 weeks of training and my learning outcomes fulfill the requirements of training for the award of relevant certificate, Lovely skillful Nasser.

I feel fortunate to have learnt the basics of CATIA V5 as a part of Workshop training at Beihang International School. I would like to thank all the people who guided or helped me in any way during my training. I was really impressed by the knowledge and way of teaching of my mentor Mr. Nasser, who was always there wherever I needed help after training. He encouraged me to ask questions making us more aware of what we were learning. It was a very good experience learning the software and has proved to be very fruitful. I could not have done this training without the help of my friends who supported me through the training.

Learning with Catia

Its objective is to promote Computer Education and Technology all over the world. Therefore, CETPA education includes:

- CATIA and AUTOCAD.
- C Language.
- Solid Edge, Siemens certified.
- Linux.
- ORACLE.
- MATLAB.
- JAVA
- WEB Designing and WEB hosting.

To make it clearer, here are some basic concepts:

- **CETPA:** Computer Education and Technology Promotion Association was established in 2002 at Roorkee and now having 6 branches across the Globe.
- **CETPA InfoTech Pvt. Ltd. is an ISO 9001:2008** is a Certified Multinational Organization which deals in the field of Software Development & Embedded Products Development, Placement Consultancy and Engineers Training Programs.
- **ET PA Info Tech** has combined unparalleled experience, comprehensive capabilities, and extensive research.
- **CAM/CAE commercial software:** It is written in C++ programming language. This Mechanical Engineering CADD (Computer Aided Designing and Drafting) software is used in various industries like Automobile, Aerospace, Consumer goods etc.
- **CATIA V5** provides three basic platforms: P1, P2, and P3.
- **P1** is for small and medium sized companies that wish to grow towards the large scale.
- **P2** is for the advanced design engineering companies that require product, process, and resource modeling.
- **CATIA V5** stands for Computer Aided Three-Dimensional Interactive Application Version 5.

It was developed by Dassault Systems, France. It is multi-platform CAD/P3-is for high-end design application and is basically for automotive and aerospace industries.

Commonly referred to as a 3D product life cycle management software suite, CATIA supports multiple stages of product development, including conceptualization, (CAD) design, engineering (CAE) and manufacturing (CAM). CATIA enables the creation of 3D parts, from 3D sketches, sheet metal composites and molded, forged or tooling parts up to the definition of mechanical assemblies. The software provides advanced technologies for mechanical surfacing. It provides tools to complete product definition, including functional tolerances as well as kinematic definition.

CATIA offers a solution to shape design (Jinfeng, 1999), styling, surfacing workflow and visualization to create, modify, and validates complex innovative shape. Also, CATIA supports multiple stages of product design whether started from scratch or from 2D sketches. CATIA can read and produce STEP form files for reverse engineering and surface reuse.

Modules/Workbenches in CATIA V5

- **Sketcher:** This workbench contains various tools with which we can create the required sketches for various operations. It is an environment where we create a profile of solid model through use of its sketch tools with constraints
- **Specification tree:** It contains all the information of the steps which we use to make the sketch in sketch workbench, part in part modeling workbench, assembly in assembly workbench etc.
- **Compass:** is used to manipulate the part, assembly. It appears on the top right corner of the geometry area.
- **Part Modeling:** After the completion of sketch, it can be converted into a 3-D model by changing workbench and using the part modeling tools. Start→ Mechanical Design→ Part Modeling

There are various tools that are used to convert a sketch into a part

They are as follows

- **Pad:** is used to extrude profile in one or both direction with adding material within limits. Insert→ Sketch based feature → Pad Pocket, which is used to remove material from existing part within limits. It is justopposite to pad. Insert→ Sketch based feature→ Pocket.
- **Shaft:** It is used to create a material by revolving a profile around selected axis. Insert→ Sketch based feature→ Shaft Groove: It is used to remove material from existing body through revolve profilearound selected axis. Insert→ Sketch based feature→ Groove.
- **Hole:** Hole command is used to create hole in existing body by giving its parameters. Insert→ Sketch based feature→ Hole.
- **Rib:** It is used to create material by sweeping a profile along a center curve. Insert→ Sketch based feature→ Rib.
- **Slot:** It is used to remove material.

There are certain other features that come under the category of Dress Up Features and Transformation Features

From existing part through a profile having a center curve. Insert→ Sketch based feature→ Slot.

These are as follows:

- Edge Fillet.
- Chamfer.
- Draft Angle.
- Shell.

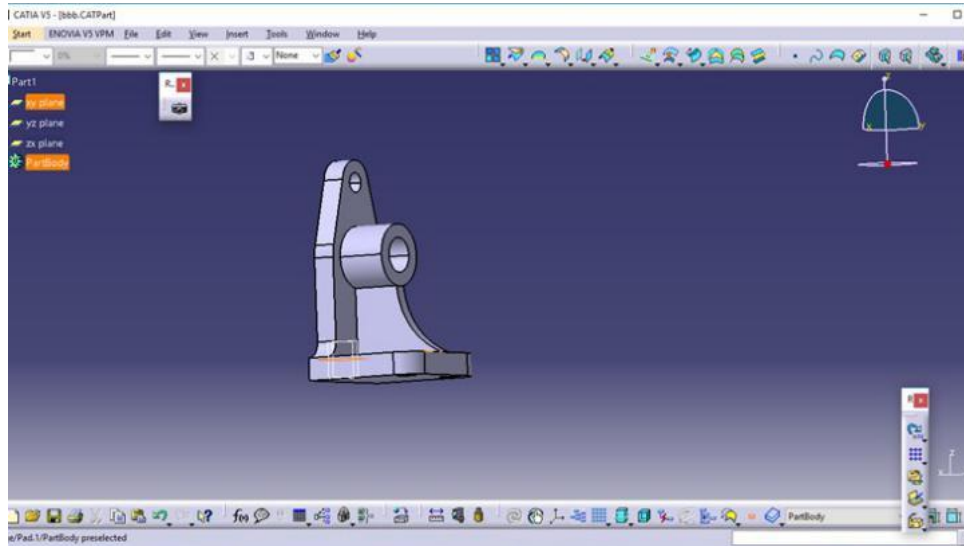

There are certain constraints that are to be applied to form a perfect assembly

The constraints are:

- **Fix:** The fix constraint is used to fix the location of the selected component in the 3-Dspace. Once the orientation of the component is fixed, its orientation cannot be changed. Insert→ Fix.
- **Coincidence constraint:** It is used to coincide the central axis of the cylindrical features that are selected from two different components. This option is also used to apply the coincident constraint between edges, points, planes or faces. Insert→ Coincidence.
- **Contact:** It is applied to make a surface-to-surface contact between two selected elements from two different components. Insert→ Contact.

- **Offset constraint:** It is used to place the selected elements at an offset distance from each other. It also makes two planar faces parallel to each other. Insert→ Offset.
- **Angle constraint:** It is used to position two geometric elements at a particular angle with respect to each other. You can also make two selected elements parallel or perpendicular to each other. Insert→ Angle.

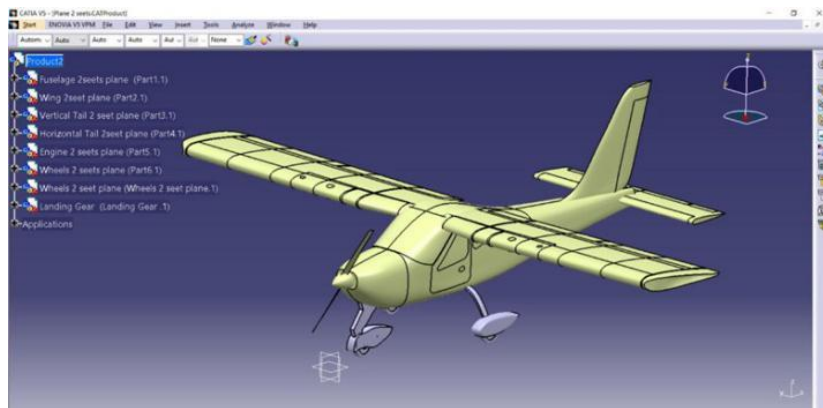

REFERENCES

Jinfeng, P. K. (1999). Development of a new tool for building 3D parametrization parts library based on CATIA software. *J Mech Sci Technol*, 1.

Fuentes de financiamiento: Esta investigación fue financiada con fondos del autor.

Declaración de conflicto de intereses: El autor declara que no tiene ningún conflicto de interés.

Copyright (c) 2021 Ater Maluth Manyaqng



Este texto está protegido por una licencia [Creative Commons 4.0](https://creativecommons.org/licenses/by/4.0/).

Usted es libre para Compartir —copiar y redistribuir el material en cualquier medio o formato— y Adaptar el documento —remezclar, transformar y crear a partir del material— para cualquier propósito, incluso para fines comerciales, siempre que cumpla la condición de:

Atribución: Usted debe dar crédito a la obra original de manera adecuada, proporcionar un enlace a la licencia, e indicar si se han realizado cambios. Puede hacerlo en cualquier forma razonable, pero no de forma tal que sugiera que tiene el apoyo del licenciente o lo recibe por el uso que hace de la obra.

[Resumendelicencia](#) - [Textocompletodelalicencia](#)